



CB 840

LIST OF THE EXPLODED VIEWS



SHELL ASSY

COOLING SYSTEM

HYDRAULIC CIRCUIT

ELECTRIC PARTS

Rev. 11 - 20/06/2011



CB 840

SHELL ASSY

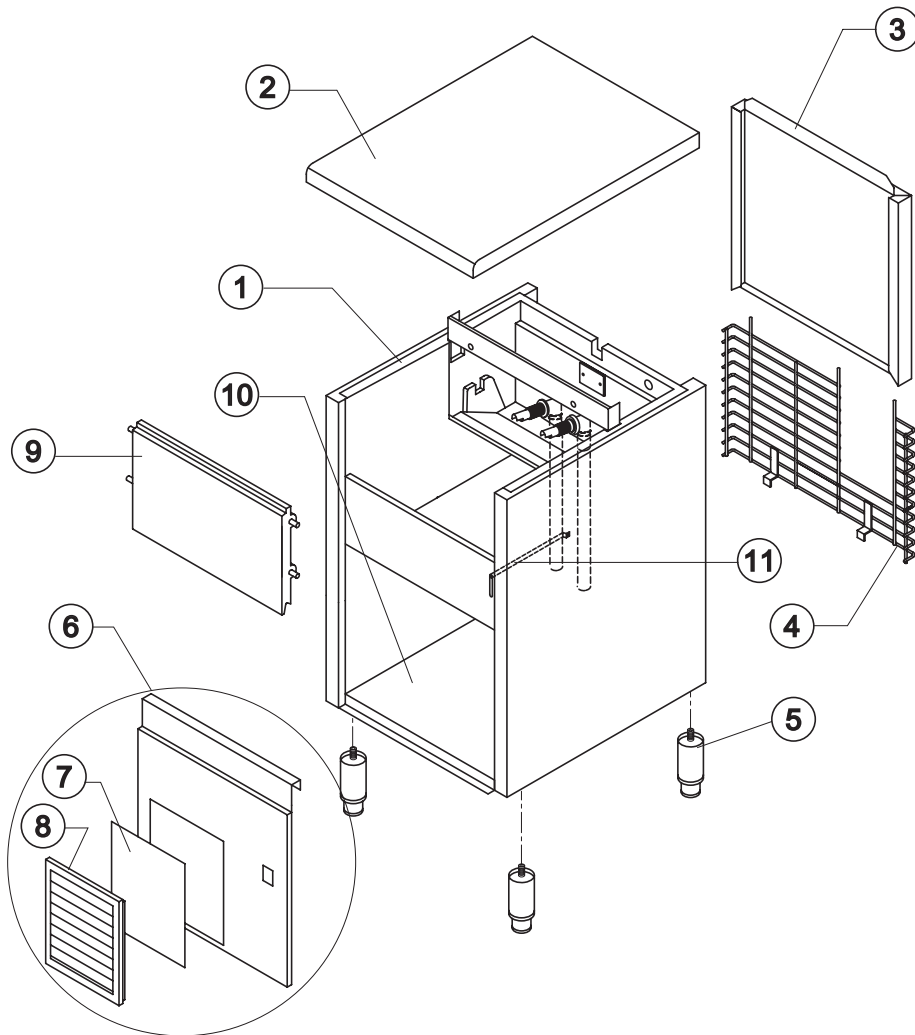

Ref.	Spare Description	Code	
1	Foamed Cabinet Assy	See Table	
2	Top Assembly	C22673	
3	Rear Panel Assembly	C21184	
4	Rear Grid	D12015	
5	Adjustable Stainless Steel Foot	20613	
6	Front Grid Panel	C22509	
7*	Filtering Panel	18106	
8	Frame + Grid & Filter	C10205	
9	Door Assy	C10275	
10	Base Plate	21280	
11	Bulb-holder Pipe	Current Version	20521
11	Bulb-holder Pipe	Till s/n. 258692	20520

Ref. 1 - Foamed Cabinet Assy

Condensation	Code
Air	C11009A
Water	C11009W

Rev. 11 - 20/06/2011



CB 840

COOLING SYSTEM

Common Parts

Ref.	Spare Description	Code
5	Sucking Fan	10213
6	Fan Fixing Hub	10014
7	Evaporator Cover Panel	Current Version 10448
7	Evaporator Cover Panel	Till s/n. 224658 10039
8	Evaporator	See Table -
9*	Solid Core Drier	14089
10	Compressor	See Table -
11	Vacuum-Charge Valve Body	14007
12*	Vacuum-Charge Valve Device	14005
13*	Vacuum-Charge Valve Plug	14006
14*	Hot Gas Valve Coil	See Table -
15*	Hot Gas Valve Body	20410

Parts for Air-Cooled Version Only

Ref.	Spare Description	Code
1	Air Condenser	20264
3	Air Condenser Conveyor	10163
4	Sucking Fan	20031

Parts for Water-Cooled Version Only

Ref.	Spare Description	Code
2	Water Condenser	14034
4	Sucking Fan	Till s/n. 221034 10213

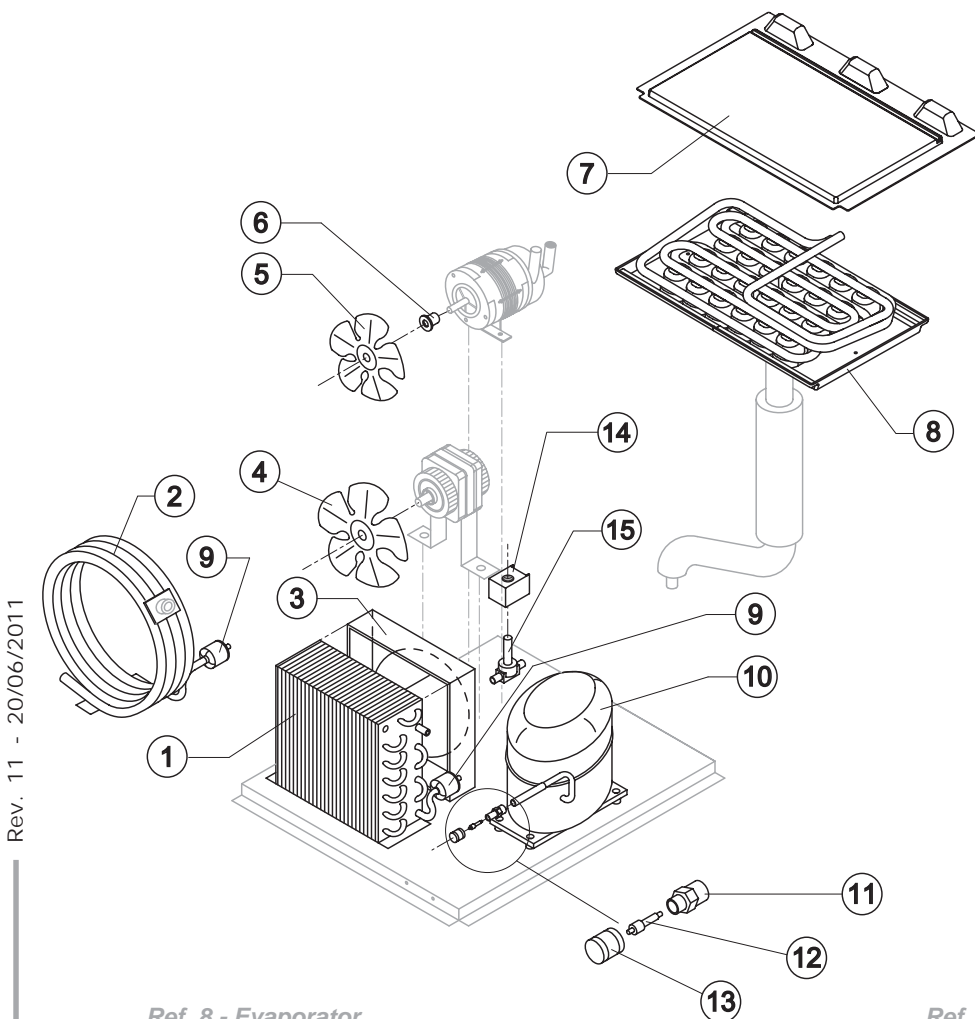

Ref. 8 - Evaporator

Kind of Cube	Code
18 g. (Standard)	D10047
33 g.	D10090
13 g.	D10418
42 g.	D10480

Ref. 10 - Compressor

Voltage	Code
T11	23875
T12	23504A
T13	23552
T19	23552

Ref. 14* - Hot Gas Valve Coil

Voltage	Code
T11	23091
T12	23091
T13	23256
T19	23256

Rev. 11 - 20/06/2011



CB 840

HYDRAULIC CIRCUIT

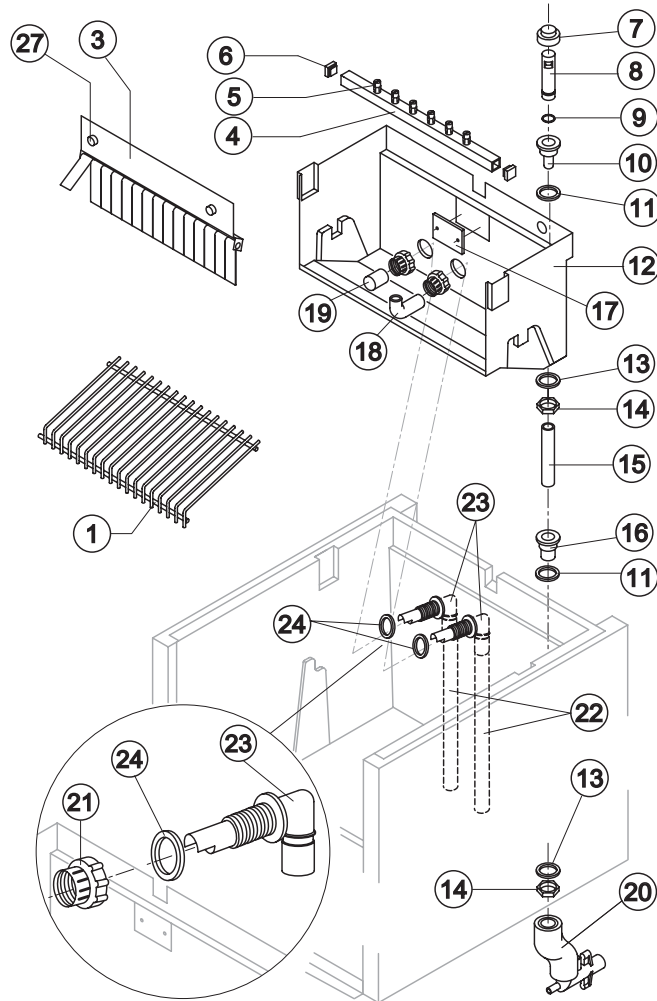

Ref. 1 - Ice Cube Slide

Kind of Cube	Code
18 g. (Standard)	D12017
33 g.	D12031
13 g.	D12039
42 g.	D12071

Ref. 4* - Sprayers Bar Ass.

Kind of Cube	Code
18 g. (Standard)	C20058
33 g.	C20156
13 g.	C20190
42 g.	C20802

Common Parts

Ref.	Spare Description	Code
1	Ice Cubes Slide	See Table
3	Flags Support Assy	C22059
4*	Sprayers Bar Assembly	See Table
5	Sprayer	D20002
6	Sprayers Bar Plug	10012
7*	Overflow Cap	10305
8*	Overflow Pipe	10133
9*	OR Gasket for Overflow Pipe	20233
10	Overflow Pipe Nipple	10471
11	Silicone Gasket	13006
12	Inner Basin	10034
13	Semirigid Polyethylene Gasket	13007
14	Bin Discharge Nut	10096
15*	Overflow Pipe	13109
16	Water Outlet Nipple	10472
17	Slide Keep Plate	Till s/n. 227891 10009
18	Sprayers Feeding Pipe	13005
19*	Pump Suction Filter	20005
21	Fittings Locking Ring	10405
22	Pump Suction/Delivery Pipe	13140
23	Fitting of the Pump Suction/Delivery Pipes	10404
24	Gasket for Pump Suction/Delivery Pipes	13143
27	Fixing Screw	20009

Parts for Air Cooled Version Only

Ref.	Spare Description	Code
20	Discharges Manifold	C10006

Parts for Water Cooled Version Only

Ref.	Spare Description	Code
20	Discharges Manifold	C26452

Rev. 11 - 20/06/2011



CB 840

ELECTRIC PARTS

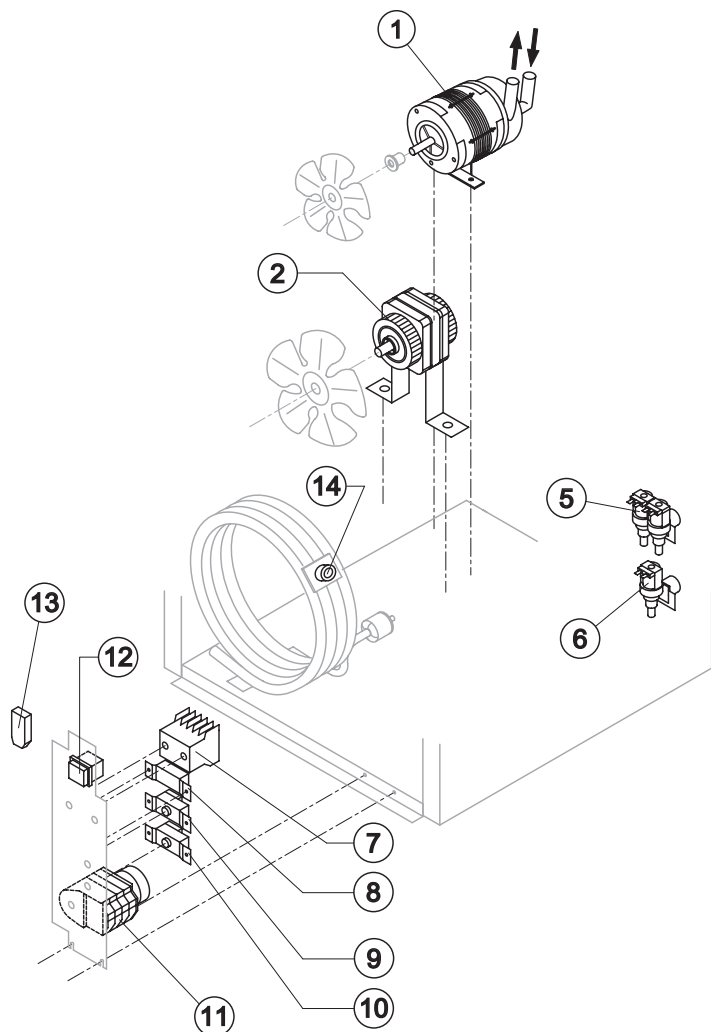

Common Parts

Ref.	Spare Description	Code
1*	Pump Assy	See Table -
2*	Fan Motor	See Table -
7	Contactor	Only T13 e T19 23595
8*	Condenser Pressure Switch	See Table -
9*	Bin Thermostat	R23005
10*	Evaporator Thermostat	R23591
11*	Timer	See Table -
12*	Green Light Switch (On-Off)	23327

Parts for Air-Cooled Version Only

Ref.	Spare Description	Code
6*	1 Way- Water Inlet Valve	See Table -
13	Anti Radio Interference Filter	Only T11 C23459

Parts for Water-Cooled Version Only

Ref.	Spare Description	Code
5*	2 Ways- Water Inlet Valve	See Table -
13	Anti Radio Interference Filter	Only T11 C23457
14*	Safety Thermostat	C23114

Ref. 1* - Pump Assy

Voltage	Code
T11	C23377
T12	C23377
T13	C23663
T19	C23663

Ref. 2* - Fan motor

Tension	Air	Water Till s/n. 221034
T11	23067	23029
T12	23681	23029
T13	23621	23683
T19	23621	-

Ref. 5* - 2 Ways- Water inlet valve

Voltage	Cube 18g/13g	Cube 33g	Cube 42g
T11	23010	23010	23781
T12	23010	23781	23781
T13	23261	23758	23758
T19	23261	23758	23758

Ref. 6* - 1 Way - Water Inlet valve

Voltage	Cube 18g/13g	Cube 33g	Cube 42g
T11	23001	23001	23220
T12	23001	23220	23220
T13	23260	23281	23281
T19	23260	23281	23281

Ref. 8* - Cond. Pressure Switch

Voltage	Code
T11	23175
T12	23175
T13	23175
T19	23680

Ref. 11* - Timer

Voltage	18g Cube	33g Cube	13g Cube	42g Cube
T11	23222	23248	23247	23780
T12	23248	23780	23247	23780
T13	23259	23786	23258	23786
T19	23259	23786	23258	23786

Rev. 11 - 20/06/2011