



IC 24

# LIST OF THE EXPLODED VIEWS



*SHELL ASSY*

*COOLING SYSTEM*

*HYDRAULIC CIRCUIT*

*SPRAYER PUMP*

*ELECTRIC PARTS*

Rev. 8 - 21/06/2011



# IC 24

# SHELL ASSY

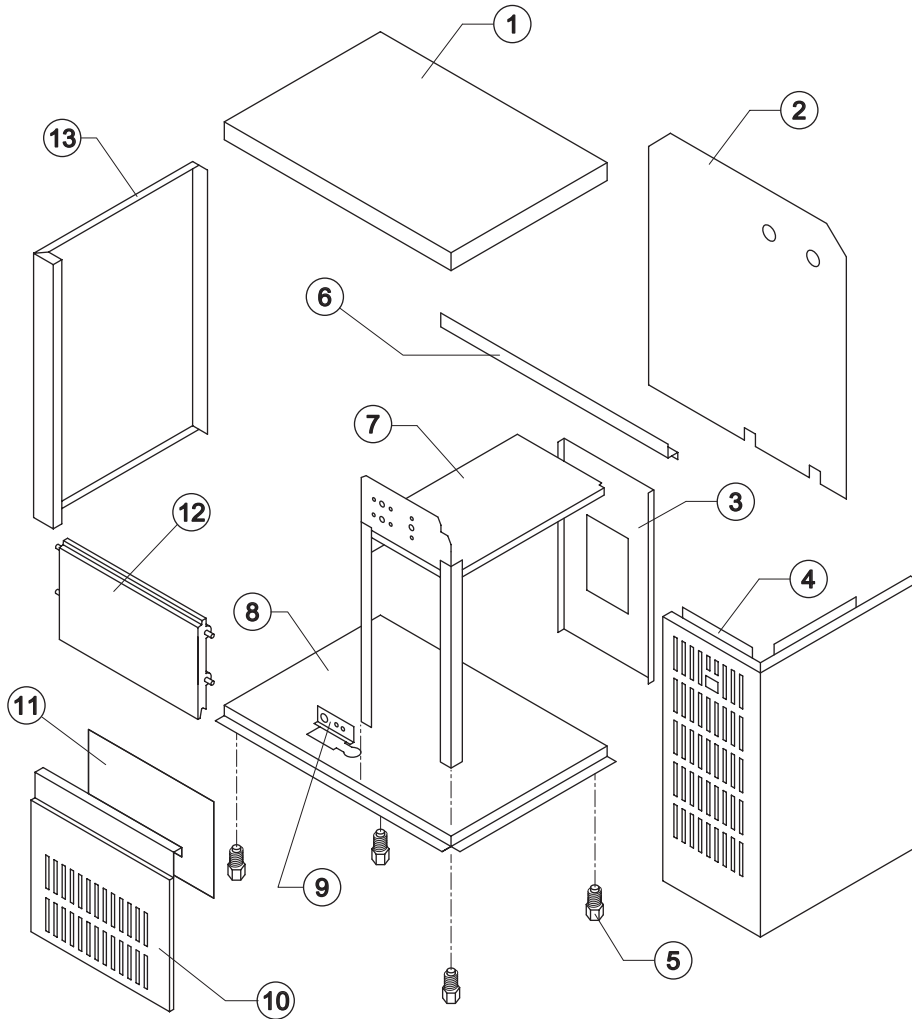

Ref.	Spare Description	Code
1	Top Assembly	C22298
2	Rear Panel	21152
3	Rear Plate	21151
4	Right + Front Panel (Fan Side)	22297
5	Foot	10017
6	Cross Bar for Rear Panel	21163
7	Fan Motor + Electrical Parts Support Plate	22296
8	Base Plate	21153
9	Support (Watervalue & Discharge)	21149
10	Front Panel	22300
11*	Filtering Panel	18106
12	Door Assy	C10303
13	Left Side Panel	22299

Rev. 8 - 21/06/2011

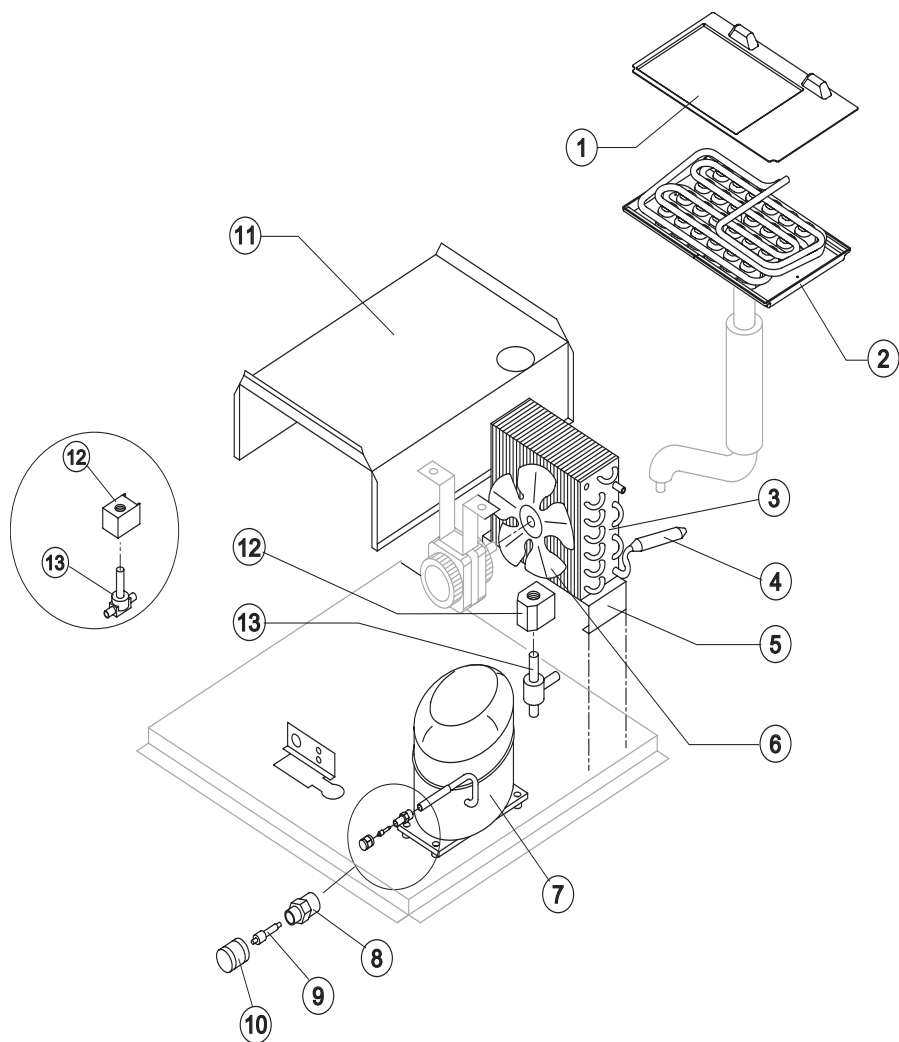

Ref.	Spare Description	Code
1	Evaporator Cover Panel	Current Version
1	Evaporator Cover Panel	Till s/n. 233365
2	Evaporator	See Table
3	Air Condenser	20260
4*	Molecular Drier	14009
5	Air Condenser Support	21148
6	Sucking Fan	20095
7	Compressor	See Table
8	Vacuum-Charge Valve Body	14007
9*	Vacuum-Charge Valve Device	14005
10*	Vacuum-Charge Valve Plug	14006
11	Bin Support Frame	21150
12*	Hot Gas Valve Coil	See Table
13*	Hot Gas Valve Body	20410

### Ref. 2 - Evaporator

Kind of Cube	Code
18 g. (Standard)	D10045
33 g.	-
13 g.	D10416

### Ref. 7 - Compressor

Tension	Code
T11	23886
T12	23494
T13	23446

### Ref. 12\* - Hot Gas Valve Coil

Tension	Code
T11	23091
T12	23091
T13	23256



# IC 24

# HYDRAULIC CIRCUIT

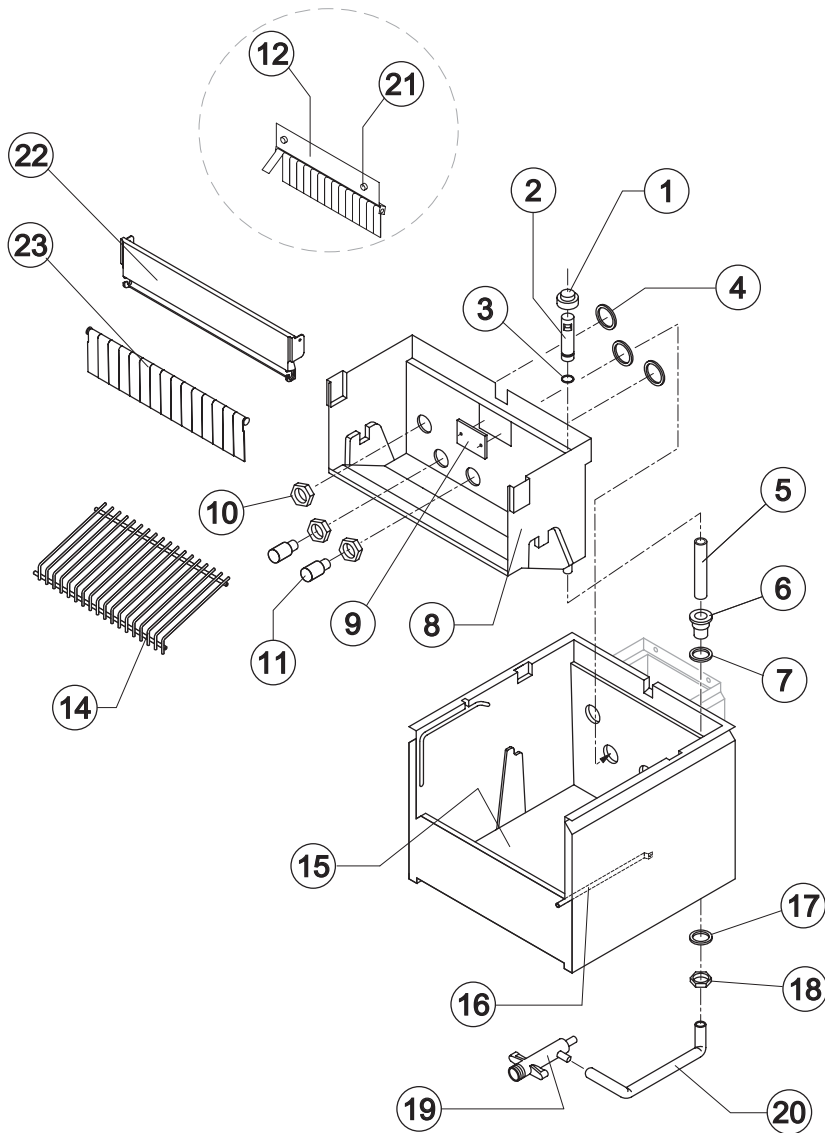

Ref.	Spare Description	Code	
1*	Overflow Cap	10305	
2*	Overflow Pipe	10133	
3*	OR Gasket for Overflow Pipe	20233	
4	Silicone Seal for Pump Basin	13069	
5*	Overflow Pipe	13105	
6	Water Outlet Nipple	10472	
7	Silicone Gasket	13006	
8	Inner Basin	10158	
9	Slide Keep Plate	10009	
10	Nut for Basin Connections	10159	
11*	Pump Suction Filter	20005	
12	Panel with Flags	Till s/n. 381652	C22034
14	Ice Cubes Slide	See Table	-
15	Foamed Basin	RC11121	
16	Bulbe-holder Pipe	20520	
17	Semirigid Polyethylene Gasket	13007	
18	Bin Discharge Nut	10096	
19	Discharges Manifold	10006	
20	Water Discharge Pipe	13066	
21	Fixing Screw	Till s/n. 381652	20009
22	Flags ABS Support	Current Version	10529
23	Rod with Flags	Current Version	C10533

### Ref. 14 - Ice Cubes Slide

Kind of Cube	Code
18 g. (Standard)	D12001
33 g.	-
13 g.	D12046

Rev. 8 - 21/06/2011

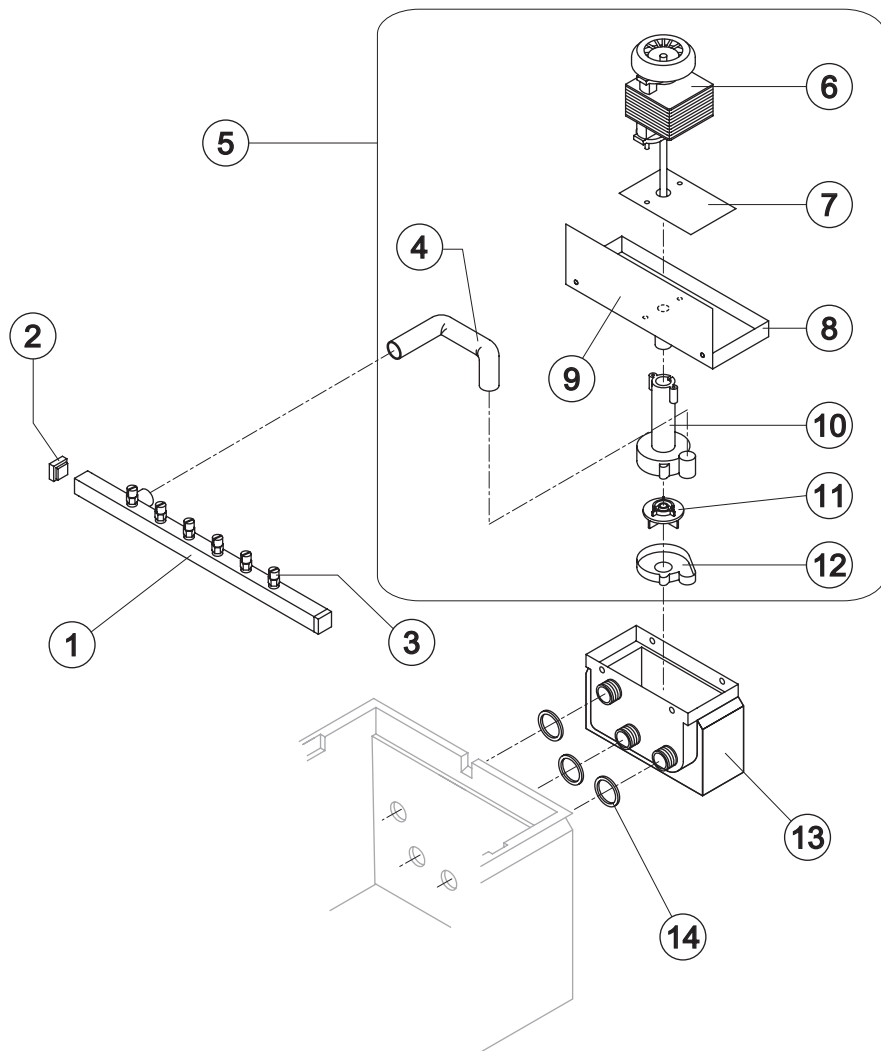

Ref.	Spare Description	Code
1*	Sprayers Bar Assembly	See Table -
2	Sprayers Bar plug	10012
3	Sprayer	D20002
4	Pump Delivery Pipe	13068
5*	Pump Assembly	See Table -
6	Pump	See Table -
7	Heat Dissipator	22430
8	Pump Motor Holder	10161
9	Basin/Pump Fender Case	22763
10	Pump Body	10065
11	Pump Impeller	10066
12	Diffusor	10067
13	Insulated Pump Basin	C11048
14	Silicone Seal for Pump Basin	13069

### Ref. 1\* - Sprayers Bar Assembly

Kind of Cube	Code
18 g. (Standard)	C20572
33 g.	-
13 g.	C20570

### Ref. 5\* - Pump Assembly

Tension	Code
T11	C23254
T12	C23416
T13	C23417

### Ref. 6 - Pump

Tension	Code
T11	23073
T12	23187
T13	23188

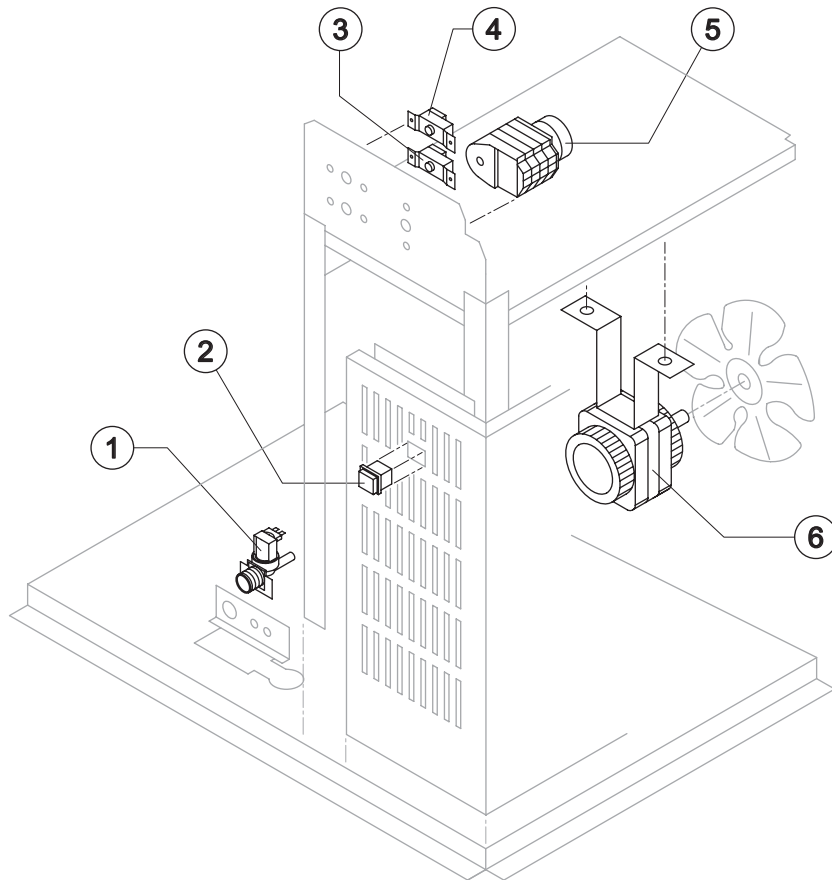

Ref.	Spare Description	Code
1*	1 Way- Water Inlet Valve	See Table
2*	Green Light Switch (On-Off)	23327
3*	Evaporator Thermostat	R23591
4*	Bin Thermostat	R23005
5*	Timer	See Table
6*	Fan Motor	See Table

### Ref. 1\* - 1 Way- Water Inlet Valve

Tension	Code
T11	23300
T12	23300
T13	23415

### Ref. 5\* - Timer

Tension	18g Cube	33g Cube	13g Cube
T11	23222	-	23247
T12	23248	-	23247
T13	23259	-	23258

### Ref. 6\* - Fan Motor

Tension	Code
T11	23029
T12	23029
T13	23683